



2025

A NEW WAY TO EXPERIENCING THE CITY

Alpina



Alpina

Via Archimede, 485
47521 Cesena (FC)
ITALY

T. +39 0547 645699
F. +39 0547 645783
info@alpinabike.com



CATALOGO 2025



INDICE

Cartella colori 2025.....	5
C1 TRK 28 ANTHEA MAN.....	6-7
C1 TRK 28 ANTHEA LADY.....	8-9
Schede tecniche.....	10-11
Q1 TRK 28 ATLANTA MAN.....	12-13
Q1 TRK 28 ATLANTA LADY.....	14-15
Q2 CITY 26 AURORA LADY.....	16-17
I1 CITY 28 ARIS MAN.....	20-21
I1 CITY 28 ARIS LADY.....	22-23
Schede tecniche.....	24-25
V1 CITY 27,5 AGAVE MAN.....	26-27
V1 CITY 27,5 AGAVE LADY.....	28-29
F3 FAT 20 ASSO.....	30-31
P1 PIEGHEVOLE 20 ARKÈ.....	32-33
P2 PIEGHEVOLE 20 AMANTEA.....	34-35
A3 MONOTUBO 28 ATHENA.....	36-37
A4 MONOTUBO 26 AGORÀ.....	38-39
B4 MONOTUBO 26 BETA.....	40-41
Fattori che determinano l'AUTONOMIA.....	42-43
Contatti / Contacts.....	44





CARTELLA COLORI

COLOR CARD 2025



					
Nero <i>Black</i>	Grigio alabastro <i>Alabaster grey</i>	Blu notte <i>Night blue</i>	Verde militare <i>Military green</i>	Ghiaia <i>Gravel</i>	Crema <i>Cream</i>
					
Azzurro pastello <i>Light blue crayon</i>	Petrolio <i>Petroleum</i>	Menta <i>Mint</i>	Blu Capri <i>Army blue</i>	Giallo pastello <i>Yellow crayon</i>	Rosso vino <i>Red wine</i>

E stands for #Evolution and #Emotion, as we proudly present each season's nobelities that ignite our passion.

V stands for the #Vision to dream together with you, as you embark on new journeys and explore new destinations.

O stands for the #Pride of creating handcrafted, made in italy products.

L stands for the #Lightness that a nice bike ride brings, a perfect escape from teh daily routine.

C1 TRK 28 ANTHEA MAN

Caratteristiche tecniche
Technical data

TELAIO / FRAME	alloy 6061 mm 500
FORCELLA / FORK	Suntour NEX ML
GUARNITURA / CRANKSET	Samox alloy 42t
COMANDI / SHIFTER	st-ef 7v
CAMBIO POST / REAR DERAILL	Shimano RD-M310 Altus
RUOTA LIBERA / FREEWHEEL	Shimano TY21 7 speed
MANUBRIO / HANDLEBAR	over trk 28
PIANTONE / STEM	alloy h.s. adjustable iso 4210
LEVE FRENO / BRAKE LEVEL	hydraulic brake
FRENI / BRAKES	hydraulic brake
LUCI / LIGHT	homologated Ger
REGGISSELLA / SEATPOST	Spanninga Ger
SELLA / SADDLE	SMP comfort
MOZZI / HUB	alloy qr/qr 36h
COPERTURE / TYRES	Rubena 700x48 antipuncture
PEDALI / PEDALS	alloy
IMBALLO / BOX	190 - m3 0,35
SCHERMO / DISPLAY	Oli-ebike LCD colored
MOTORE / ENGINE	Oli-ebike central moto 60N
AUTONOMIA / AUTONOMY	fino a 130 km
BATTERIA / BATTERY	integrated battery 14ah (504 wh)

MADE IN ITALY

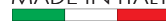

Nero
Black



Grigio alabastro
Alabaster grey



Blu notte
Night blue



C1 TRK 28 ANTHEA LADY

Caratteristiche tecniche

Technical data

TELAIO / FRAME	alloy 6061 mm 460
FORCELLA / FORK	Suntour NEX ML
GUARNITURA / CRANKSET	Samox alloy 42t
COMANDI / SHIFTER	shimano st-ef 7v
CAMBIO POST / REAR DERAILL	Shimano RD-M310 Altus
RUOTA LIBERA / FREEWHEEL	Shimano TY21 7 speed
MANUBRIO / HANDLEBAR	over trk 28
PIANTONE / STEM	alloy adjustable iso 4210
LEVE FRENO / BRAKE LEVEL	shimano hydraulic brake
FRENI / BRAKES	shimano hydraulic brake
LUCI / LIGHT	homologated Ger
REGGISSELLA / SEATPOST	alloy w/suspension
SELLA / SADDLE	SMP comfort
MOZZI / HUB	alloy qr/qr 36h
COPERTURE / TYRES	Rubena 700x48 antipuncture
PEDALI / PEDALS	alloy
IMBALLO / BOX	190 - m3 0,35
SCHERMO / DISPLAY	Oli-ebike LCD colored
MOTORE / ENGINE	Oli-ebike central moto 60N
AUTONOMIA / AUTONOMY	fino a 130 km
BATTERIA / BATTERY	integrated battery 14ah (504 wh)

MADE IN ITALY

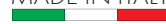

EVOJ
FABBRICA ITALIANA



Nero
Black



Grigio alabastro
Alabaster grey



Blu notte
Night blue



Motore SPORT-ONE



MADE IN ITALY

SPORT-ONE

Code:	SPORT-ONE
Rated Power:	250W
Rated Voltage:	36V
Max Torque:	60Nm
Internal Gear:	2
Weight:	3,2Kg
Communication:	UART
Fixing Holes Pattern:	2x3 M8 proprietary pattern
Q-Factor:	178mm
Chain-line:	52mm (142mm/148mm boost)
Crank interface:	ISIS
Chainring options:	BCD 104 - 30/44T
Coaster brake option:	Yes
Chain-guide and bashguard:	Yes
Applications:	City, Gravel, long-distance
Availability:	Mass Production



DISPLAY HIGH vision

Code:	DISPHV
Screen Size:	2"
Handlebar bracket:	31,8 mm
Twilight Sensor:	Yes
Remote Controller:	Yes
Walk Mode:	Yes, on remote
BT/ANT+ Connectivity:	Q4 2021
Communication:	CANBUS/UART
Custom logo at startup:	Yes
Availability:	Mass production

2" High-definition TFT display Packed in a slim and elegant design it seamlessly integrates with any handlebar. Thanks to its dualsided bracket that firmly holds it right in front of the stem, you can access any info at first sight.

On top of those common functionalities, the HIGH Vision features:

- Motor power output
- Rider power
- Automatic light switch
- Dark mode
- Gorilla-Glass® anti reflective screen
- IP68 certified

Display HIGH vision



GHOST Fully Integrated

GHOST 540

Code:	GHOST540
Pack:	10S5P
Cell Type:	18650
Cell Brand:	BAK
Dimensions (mm):	411 x 63 x 85
Nominal Voltage:	36V
Nominal Capacity:	15Ah - 540Wh
Communication:	Canbus
Weight:	3.2Kg
Compliance EN 15194:2017	Yes
Availability:	Q1 2022



Alpina

Q1 TRK 28 ATLANTA MAN

Caratteristiche tecniche
Technical data

TELAIO / FRAME	alloy 6061 mm 480
FORCELLA / FORK	suspension fork ML
GUARNITURA / CRANKSET	PRW alloy
COMANDI / SHIFTER	Revo RS36 7s
CAMBIO POST / REAR DERAILL	Shimano TY300
RUOTA LIBERA / FREEWHEEL	Shimano TY21 7 speed
MANUBRIO / HANDLEBAR	alloy Iso 4210
PIANTONE / STEM	alloy adjustable
LEVE FRENO / BRAKE LEVEL	alloy
FRENI / BRAKES	mechanical disk brake
LUCI / LIGHT	Buchel Ger
REGGISSELLA / SEATPOST	alloy
SELLA / SADDLE	SMP soft
MOZZI / HUB	alloy disk
COPERTURE / TYRES	Mitas 700x48 antipuncture
PEDALI / PEDALS	no slip
IMBALLO / BOX	190 - m3 0,35
SCHERMO / DISPLAY	LCD 5 levels PAS
MOTORE / ENGINE	rear moto 45N
AUTONOMIA / AUTONOMY	fino a 90 km
BATTERIA / BATTERY	integrated battery 14ah (504 wh)

MADE IN ITALY

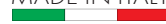

Nero
Black



Ghiaia
Gravel



Verde militare
Military green



EVOJ
FABBRICA ITALIANA

Q1 TRK 28 ATLANTA LADY

Caratteristiche tecniche
Technical data

TELAIO / FRAME	alloy 6061 mm 440
FORCELLA / FORK	suspension fork ML
GUARNITURA / CRANKSET	PRW alloy
COMANDI / SHIFTER	Revo RS36 7s
CAMBIO POST / REAR DERAILL	Shimano TY300
RUOTA LIBERA / FREEWHEEL	Shimano TY21 7 speed
MANUBRIO / HANDLEBAR	alloy Iso 4210
PIANTONE / STEM	alloy adjustable
LEVE FRENO / BRAKE LEVEL	alloy
FRENI / BRAKES	mechanical disk brake
LUCI / LIGHT	Buchel Ger
REGGISSELLA / SEATPOST	alloy
SELLA / SADDLE	SMP soft
MOZZI / HUB	alloy disk
COPERTURE / TYRES	Mitas 700x48 antipuncture
PEDALI / PEDALS	no slip
IMBALLO / BOX	190 - m3 0,35
SCHERMO / DISPLAY	LCD 5 levels PAS
MOTORE / ENGINE	rear moto 45N
AUTONOMIA / AUTONOMY	fino a 90 km
BATTERIA / BATTERY	integrated battery 14ah (504 wh)

MADE IN ITALY

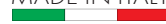

Nero
Black



Verde militare
Military green



Ghiaia
Gravel



EVOJ
FABBRICA ITALIANA

Q2 CITY 26

AURORA

LADY

Caratteristiche tecniche

Technical data

TELAIO / FRAME	alloy 6061 26 x 420
FORCELLA / FORK	suspension fork ML
GUARNITURA / CRANKSET	PRW alloy
COMANDI / SHIFTER	Revo RS36 7s
CAMBIO POST / REAR DERAIL	Shimano TY300
RUOTA LIBERA / FREEWHEEL	Shimano TY21 7 speed
MANUBRIO / HANDLEBAR	alloy Iso 4210
PIANTONE / STEM	alloy adjustable
LEVE FRENO / BRAKE LEVEL	alloy
FRENI / BRAKES	mechanical disk brake
LUCI / LIGHT	Buchel Ger
REGGISSELLA / SEATPOST	alloy
SELLA / SADDLE	SMP soft
MOZZI / HUB	alloy disk
COPERTURE / TYRES	Mitas 700x48 antipuncture
PEDALI / PEDALS	no slip
IMBALLO / BOX	190 - m3 0,35
SCHERMO / DISPLAY	LCD 5 levels PAS
MOTORE / ENGINE	rear moto 45N
AUTONOMIA / AUTONOMY	fino a 90 km
BATTERIA / BATTERY	integrated battery 14ah (504 wh)

MADE IN ITALY

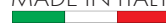

Nero
Black



Crema
Cream



Azzurro pastello
Light blue crayon



EVOJ
FABBRICA ITALIANA



11 CITY 28

ARIS

MAN

Caratteristiche tecniche

Technical data

TELAIO / FRAME	alloy 6061 mm 500
FORCELLA / FORK	steel 1"1/8
GUARNITURA / CRANKSET	PRW alloy
COMANDI / SHIFTER	Shimano RS46 7s
CAMBIO POST / REAR DERAILL	Shimano TY300
RUOTA LIBERA / FREEWHEEL	Shimano TY21 7 speed
MANUBRIO / HANDLEBAR	alloy Iso 4210
PIANTONE / STEM	alloy adjustable
LEVE FRENO / BRAKE LEVEL	alloy
FRENI / BRAKES	mechanical disk brake
LUCI / LIGHT	Buchel Ger
REGGISSELLA / SEATPOST	alloy
SELLA / SADDLE	SMP soft
MOZZI / HUB	alloy disk
COPERTURE / TYRES	Mitas 700x48 antipuncture
PEDALI / PEDALS	no slip
IMBALLO / BOX	190 - m3 0,35
SCHERMO / DISPLAY	LCD 5 levels PAS
MOTORE / ENGINE	rear moto 45N
AUTONOMIA / AUTONOMY	fino a 50 km
BATTERIA / BATTERY	battery indoor down tube 10,2ah (370wh)

MADE IN ITALY



EVOJ
FABBRICA ITALIANA



Nero
Black



Grigio alabastro
Alabaster grey



Petrolio
Petroleum



11 CITY 28

ARIS

LADY

Caratteristiche tecniche

Technical data

TELAIO / FRAME	alloy 6061 mm 500
FORCELLA / FORK	steel 1 1/8
GUARNITURA / CRANKSET	PRW alloy
COMANDI / SHIFTER	Shimano RS46 7s
CAMBIO POST / REAR DERAILL	Shimano TY300
RUOTA LIBERA / FREEWHEEL	Shimano TY21 7 speed
MANUBRIO / HANDLEBAR	alloy Iso 4210
PIANTONE / STEM	alloy adjustable
LEVE FRENO / BRAKE LEVEL	alloy
FRENI / BRAKES	mechanical disk brake
LUCI / LIGHT	Buchel Ger
REGGISSELLA / SEATPOST	alloy
SELLA / SADDLE	SMP soft
MOZZI / HUB	alloy disk
COPERTURE / TYRES	Mitas 700x48 antipuncture
PEDALI / PEDALS	no slip
IMBALLO / BOX	190 - m3 0,35
SCHERMO / DISPLAY	LCD 5 levels PAS
MOTORE / ENGINE	rear moto 45N
AUTONOMIA / AUTONOMY	fino a 50 km
BATTERIA / BATTERY	battery indoor down tube 10,2ah (370wh)

MADE IN ITALY

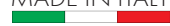

EVOJ
FABBRICA ITALIANA



Nero
Black



Grigio alabastro
Alabaster grey



Ghiaia
Gravel



Menta
Mint

Pacco batteria
BTRHL-3610



BTRHL-3610

PACK:	10S2P
CELL TYPE:	21700
CELL BRAND:	SAMSUNG
DIA.:	582.3L * 48.4W * 48.1H MML (including controller)
NOMINAL CAPACITY:	10.2 Ah - 370 Wh
COMMUNICATION:	NA
WEIGHT :	1.76KG (battery only including cells , w/o controller)
COMPLIANCE EN 15194/2017:	YES

Motore
DGW07C-MD



Display
KM3209 LED



DISPLAY KM3209 LED

SCOPE OF APPLICATION:	EN 15194
VOLT:	36
PAS LEVELS:	N°5
DIM:	mm 55 x 55,5

Rear Motor DGW07C-MD

Voltage:	36V
Design:	Brushless
Wattage:	250W,255RPM
Motor Type Brushless:	Brushless Gear Hub Motor
SKU:	MINI-DB-R
Type:	DGW07
Specification:	16-28in 36(Holes)
Rated Power:	250W
Rated Voltage:	36V
Fork size:	135mm



V1 CITY 27,5 AGAVE MAN

EVOJ
FABBRICA ITALIANA

Caratteristiche tecniche
Technical data

TELAIO / FRAME	alloy 6061 mm 420
FORCELLA / FORK	rigid fork
GUARNITURA / CRANKSET	PRW alloy
COMANDI / SHIFTER	Revo RS36 7s
CAMBIO POST / REAR DERAIL	Shimano TY300
RUOTA LIBERA / FREEWHEEL	Shimano TY21 7 speed
MANUBRIO / HANDLEBAR	alloy Iso 4211
PIANTONE / STEM	alloy adjustable
LEVE FRENO / BRAKE LEVEL	alloy
FRENI / BRAKES	mechanical disk brake
LUCI / LIGHT	Buchel Ger
REGGISSELLA / SEATPOST	alloy
SELLA / SADDLE	SMP soft
MOZZI / HUB	alloy disk
COPERTURE / TYRES	Vr 27,5x2,1
PEDALI / PEDALS	no slip
IMBALLO / BOX	191 - m3 0,35
SCHERMO / DISPLAY	LCD 5 levels PAS
MOTORE / ENGINE	rear moto 45N
AUTONOMIA / AUTONOMY	fino a 90 km
BATTERIA / BATTERY	integrated battery 14ah (504 wh)

MADE IN ITALY

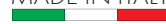

Nero
Black



Blue Capri
Capri blue



V1 CITY 27,5 AGAVE LADY

Caratteristiche tecniche

Technical data

TELAIO / FRAME	alloy 6061 mm 420
FORCELLA / FORK	rigid fork
GUARNITURA / CRANKSET	PRW alloy
COMANDI / SHIFTER	Revo RS36 7s
CAMBIO POST / REAR DERAIL	Shimano TY300
RUOTA LIBERA / FREEWHEEL	Shimano TY21 7 speed
MANUBRIO / HANDLEBAR	alloy Iso 4211
PIANTONE / STEM	alloy adjustable
LEVE FRENO / BRAKE LEVEL	alloy
FRENI / BRAKES	mechanical disk brake
LUCI / LIGHT	Buchel Ger
REGGISSELLA / SEATPOST	alloy
SELLA / SADDLE	SMP soft
MOZZI / HUB	alloy disk
COPERTURE / TYRES	Vr 27,5x2,1
PEDALI / PEDALS	no slip
IMBALLO / BOX	191 - m3 0,35
SCHERMO / DISPLAY	LCD 5 levels PAS
MOTORE / ENGINE	rear moto 45N
AUTONOMIA / AUTONOMY	fino a 90 km
BATTERIA / BATTERY	integrated battery 14ah (504 wh)

MADE IN ITALY

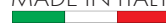

Nero
Black



Crema
Cream



Azzurro pastello
Light blue crayon



Menta
Mint

EVOJ
FABBRICA ITALIANA

F3 FAT 20 ASSO

Caratteristiche tecniche

Technical data

TELAIO / FRAME	alloy 6061
FORCELLA / FORK	suspension fork ML (lock)
GUARNITURA / CRANKSET	alloy 52 t
COMANDI / SHIFTER	shimano RS-36 7v
CAMBIO POST / REAR DERAILL	shimano tx300
RUOTA LIBERA / FREEWHEEL	shimano tz21 7v
MANUBRIO / HANDLEBAR	alloy iso 4210
PIANTONE / STEM	alloy folding
LEVE FRENO / BRAKE LEVEL	alloy
FRENI / BRAKES	disk mecnical brake
LUCI / LIGHT	homologated FRA
REGGISSELLA / SEATPOST	alloy iso 4210
SELLA / SADDLE	soft
MOZZI / HUB	alloy
COPERTURE / TYRES	20 x 4 fat bike
PEDALI / PEDALS	no slip
IMBALLO / BOX	190 m3 0m35
SCHERMO / DISPLAY	lcd
MOTORE / ENGINE	rear moto 48v
AUTONOMIA / AUTONOMY	fino a 80 km
BATTERIA / BATTERY	14 ah 



Nero
Black



P1 PIEGHEVOLE 20 ARKÈ

Caratteristiche tecniche

Technical data

TELAIO / FRAME	alloy 6061 20 x 380
FORCELLA / FORK	rigid fork
GUARNITURA / CRANKSET	alloy 42 t
COMANDI / SHIFTER	shimano RS-36 7v
CAMBIO POST / REAR DERAILL	shimano Tx300
RUOTA LIBERA / FREEWHEEL	shimano Tz21 7v
MANUBRIO / HANDLEBAR	alloy iso 4210 folding
PIANTONE / STEM	alloy folding
LEVE FRENO / BRAKE LEVEL	alloy
FRENI / BRAKES	disk mecanical brake
LUCI / LIGHT	homologated GER
REGGISSELLA / SEATPOST	with battery
SELLA / SADDLE	soft
MOZZI / HUB	alloy
COPERTURE / TYRES	20 x 3,00
PEDALI / PEDALS	folding
IMBALLO / BOX	190 m3 0,35
SCHERMO / DISPLAY	lcd
MOTORE / ENGINE	rear moto 36v
AUTONOMIA / AUTONOMY	fino a 80km
BATTERIA / BATTERY	11ah 



Nero
Black



Giallo pastello
Yellow crayon



P2 PIEGHEVOLE 20 AMANTEA

Caratteristiche tecniche

Technical data

TELAIO / FRAME	alloy 6061 20 x 400
FORCELLA / FORK	rigid fork
GUARNITURA / CRANKSET	alloy 42 t
COMANDI / SHIFTER	shimano RS-36 6v
CAMBIO POST / REAR DERAILL	shimano tx200
RUOTA LIBERA / FREEWHEEL	shimano tz20 6v
MANUBRIO / HANDLEBAR	alloy iso 4210
PIANTONE / STEM	alloy iso 4210
LEVE FRENO / BRAKE LEVEL	alloy
FRENI / BRAKES	v/brake promax homologated e-bike
LUCI / LIGHT	homologated GER
REGGISSELLA / SEATPOST	alloy iso 4210
SELLA / SADDLE	soft
MOZZI / HUB	alloy
COPERTURE / TYRES	20 x 1,75
PEDALI / PEDALS	folding
IMBALLO / BOX	190 m3 0,35
SCHERMO / DISPLAY	lcd
MOTORE / ENGINE	rear moto 36v
AUTONOMIA / AUTONOMY	fino a 60 km
BATTERIA / BATTERY	10 ah 



Nero
Black



Rosso vino
Red wine



Ghiaia
Gravel



A3 MONOTUBO 28 ATHENA

EVOJ
FABBRICA ITALIANA

Caratteristiche tecniche

Technical data

TELAIO / FRAME	alloy omologato e-bike
FORCELLA / FORK	suspension fork
GUARNITURA / CRANKSET	PRW alloy
COMANDI / SHIFTER	Shimano RS-36 6v
CAMBIO POST / REAR DERAILL	Shimano TX200
RUOTA LIBERA / FREEWHEEL	Shimano TY20 6v
MANUBRIO / HANDLEBAR	alloy Iso 4210
PIANTONE / STEM	alloy adjustable
LEVE FRENO / BRAKE LEVEL	alloy
FRENI / BRAKES	v/brake Promax homologate e-bike
LUCI / LIGHT	Buchel Ger
REGGISSELLA / SEATPOST	alloy
SELLA / SADDLE	Alpina soft
MOZZI / HUB	alloy
COPERTURE / TYRES	Mitas 700x42 antipuncture
PEDALI / PEDALS	no slip
IMBALLO / BOX	190 - m3 0,35
SCHERMO / DISPLAY	LCD 5 levels PAS
MOTORE / ENGINE	rear moto 36V 250w (promovec 3 year og warranty)
AUTONOMIA / AUTONOMY	fino a 130 km
BATTERIA / BATTERY	15,6 (567 w) 3 year of warranty

MADE IN DENMARK



Nero
Black



Ghiaia
Carvel



Menta
Mint



A4 MONOTUBO 26 AGORÀ

EVOJ
FABBRICA ITALIANA

Caratteristiche tecniche

Technical data

TELAIO / FRAME	alloy omologato e-bike
FORCELLA / FORK	suspension fork
GUARNITURA / CRANKSET	PRW alloy
COMANDI / SHIFTER	Shimano RS-36 6v
CAMBIO POST / REAR DERAILL	Shimano TX200
RUOTA LIBERA / FREEWHEEL	Shimano TY20 6v
MANUBRIO / HANDLEBAR	alloy Iso 4210
PIANTONE / STEM	alloy adjustable
LEVE FRENO / BRAKE LEVEL	alloy
FRENI / BRAKES	v/brake Promax homologate e-bike
LUCI / LIGHT	Buchel Ger
REGGISSELLA / SEATPOST	alloy
SELLA / SADDLE	Alpina soft
MOZZI / HUB	alloy
COPERTURE / TYRES	Mitas 26x1,75 antipuncture
PEDALI / PEDALS	no slip
IMBALLO / BOX	190 - m3 0,35
SCHERMO / DISPLAY	LCD 5 levels PAS
MOTORE / ENGINE	rear moto 36V 250w (promovec 3 year og warranty)
AUTONOMIA / AUTONOMY	fino a 130 km
BATTERIA / BATTERY	15,6 (567 w) 3 year of warranty

MADE IN DENMARK



Nero
Black



Ghiaia
Carvel



Menta
Mint



B4 MONOTUBO 26 BETA



Caratteristiche tecniche

Technical data

TELAIO / FRAME	alloy omologato e-bike
FORCELLA / FORK	suspension fork
GUARNITURA / CRANKSET	steel
COMANDI / SHIFTER	shimano RS-36 6v
CAMBIO POST / REAR DERAILL	shimano TY21
RUOTA LIBERA / FREEWHEEL	shimano TZ20 6v
MANUBRIO / HANDLEBAR	alloy iso 4210
PIANTONE / STEM	alloy adjustable
LEVE FRENO / BRAKE LEVEL	alloy
FRENI / BRAKES	v/brake promax homologated e-bike
LUCI / LIGHT	homologated FRA
REGGISSELLA / SEATPOST	alloy
SELLA / SADDLE	soft
MOZZI / HUB	alloy
COPERTURE / TYRES	26x1,75
PEDALI / PEDALS	no slip
IMBALLO / BOX	190 m3 0,35
SCHERMO / DISPLAY	lcd
MOTORE / ENGINE	rear moto Promovec 36v
AUTONOMIA / AUTONOMY	fino 80 km
BATTERIA / BATTERY	11 ah Promovec (3 year warranty)

MADE IN DENMARK



Nero
Black



Crema
Cream



Rosso vino
Red wine



Petrolio
Petroleum

Pacco batteria
CARRIER 6/2
promovec
the e-bike solution



Modeli: A1 15,6Ah - A3, A4 11Ah

Specifications

Rated voltage	36V
Com.Protocol	UART
BMS	Smart BMS
Voltage scope (V)	31-42V
Charghe mode	CC-CV (3 pin Pro-Movec charger)
Operation temperature charge	0°C-45°C
Backlight light	Yes

Battery options

Part.no	Name	Capacity
50637-BL-C	CAR6/2	8,8Ah, 36V, 316Wh
50663-BL-C	CAR6/2	12,8Ah, 36V, 482Wh
50368-BL-C-36V	CAR6/2-XL	11,0Ah, 36V, w/light, 396Wh
50774-BL-C-36V	CAR6/2-XL	13,2Ah, 36V, w/light, 415Wh
50775-BL-C-36V	CAR6/2-XL	15,6Ah, 36V, w/light, 562Wh
50776-BL-C-36V	CAR6/2-XL	17,4Ah, 36V, w/light, 626Wh

Mounting parameter

Position	36V
Weight (kg)	UART
Controller position	Smart BMS
Carrier	31-42V
Charger	CC-CV (3 pin Pro-Movec charger)

Tests & certifications

IP	IP65
Certifications	CE/EN 15194 ROHS / REACH UN 38,3, MSDS

Motore 50971-BL
promovec
the e-bike solution



Rear motor 50971-BL

Specifications

Position	Rear
Freewheel	Yes
Rated voltage	36V
Rated power	250W
Max. support bike speed	25 km/h
Max torque	40 Nm
Efficiency	Min. 80%
Walk assist function	Yes
Color	Black/silver
Weight	2,9 kg
Operation temperature	Max. 120°
Max RPM	250 RPM
Wheel speed sensor	Integrated
Type	BLDC w. hall sensor



Function

Compatible brake type	Disc / V-brake
-----------------------	----------------

Tests & Certification

IP classification	IP54
Certifications	CE/EN 15194/ROHS

Mounting parameters

Fork width	135 mm.
Axel diameter	Ø12 mm.
Slot width	10 mm.
Compatible brake type	Disc / V-brake

Cables & connector

Cable length	220 mm.
Connector	IP66 Plug

Spoke specifications

Flange width	40 mm.
Spoke hole center-center	28 mm.
Spoke hole diameter	Ø3 mm.

Further specifications

Compatible wheel size	26" - 29"
Rear sprocket	Cassette Shimano 8,9,10 speed

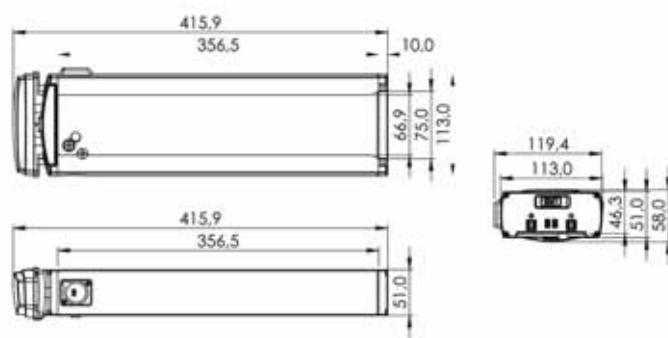
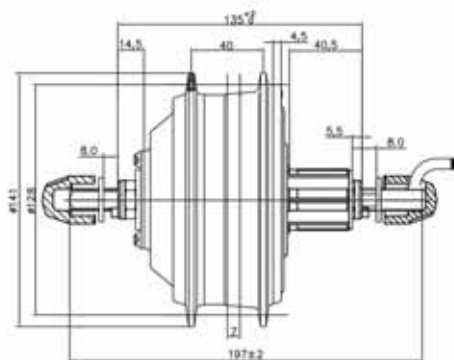

EPAC ACCORDING TO EN15194 25Km/h 250W
CONFORME AUX EXIGENCES DE SECURITE



Fattori che determinano
L'AUTONOMIA

TRAINING PERSONALE (50% rispetto-rispetto)

Conclusione: il 53% di cicli in meno con solo il 20% di sforzo proprio.

Variabile	Proprio sforzo (50%)	Proprio sforzo (20%)
Distanza percorsa	40 km	40 km
Capacità con batteria nuova da 11,6 Ah	11.600 mAh	11.600 mAh
Distanza percorribile con batteria nuova	70 km	56 km
Consumo batteria per km.	170 mAh	215 mAh
Consumo batteria per tragitto	6.800 mAh	8.600 mAh
Capacità in eccesso	4.800 mAh	3.000 mAh
Usura della capacità per tragitto	6 mAh	8 mAh
Numero cicli di pedalate	4.800/6 = 800	3.000/6 = 375

PESO DEL CICLISTA (75 kg rispetto 100 kg)

Conclusione: 15% in meno di cicli con un peso utente di 100 kg.

Variabile	Peso del ciclista 75 kg	Peso del ciclista 100 kg
Distanza percorsa	40 km	40 km
Capacità con batteria nuova da 11,6 Ah	11.600 mAh	11.600 mAh
Distanza percorribile con batteria nuova	70 km	67 km
Consumo batteria per km.	170 mAh	180 mAh
Consumo batteria per tragitto	6.800 mAh	7.200 mAh
Capacità in eccesso	4.800 mAh	4.400 mAh
Usura della capacità per tragitto	6 mAh	6,5 mAh
Numero cicli di pedalate	4.800/6 = 800	4.400/6,5 = 677

Pressione coperture (Normale rispetto bassa)

Conclusione: il 36% in meno di cicli ed il 20% in più di energia consumata

Variabile	40 km	40 km
Distanza percorsa	40 km	40 km
Capacità con batteria nuova da 11,6 Ah	11.600 mAh	11.600 mAh
Distanza percorribile con batteria nuova	70 km	60 km
Consumo batteria per km.	170 mAh	200 mAh
Consumo batteria per tragitto	6.800 mAh	8.000 mAh
Capacità in eccesso	4.800 mAh	3.600 mAh
Usura della capacità per tragitto	6 mAh	7 mAh
Numero cicli di pedalate	4.800/6 = 800	3.000/7 = 514

Utilizzo di cicli di ricarica più brevi (ad esempio casa + lavoro)

Conclusione: 71% di cicli extra se si utilizza un caricatore aggiuntivo

Variabile	40 km	40 km
Distanza percorsa	40 km	40 km
Capacità con batteria nuova da 11,6 Ah	11.600 mAh	11.600 mAh
Distanza percorribile con batteria nuova	70 km	70 km
Consumo batteria per km.	170 mAh	170 mAh
Consumo batteria per tragitto	6.800 mAh	3.400 mAh
Capacità in eccesso	4.800 mAh	8.200 mAh
Usura della capacità per tragitto	6 mAh	3 mAh
Numero cicli di pedalate	4.800/6 = 800	8.200/7 = 2733



Contatti / Contacts

ORDINI / ORDERS	sales@alpinabike.com
SPEDIZIONI / LOGISTICS	amministrazione@alpinabike.com
E-BIKES	lorenza@alpinabike.com
COMMERCIALE / SALES	sales@alpinabike.com
EXPORT	sales@alpinabike.com
MARKETING	marketing@alpinabike.com



Alpina

Via Archimede, 485
47521 Cesena (FC)
ITALY

T. +39 0547 645699

F. +39 0547 645783

info@alpinabike.com

